

Instruction Manual

AXION SERIES - ELECTRIC STRIKE

MODEL EN 800



TRINE ACCESS TECHNOLOGY
 1440 Ferris Place, Bronx, NY 10461-3699
 Phone: 718 829-2332 Fax: 718 829-6405
 www.trineonline.com



PARTS LIST

Index No.	Name	Part Number
1	Latch	EN-PLCH
2	Slider	EN-SLR
3	Coil Assembly (12 V) Coil Assembly (24 V)	EN-CA-12DC, EN-CA-12AC EN-CA-24DC, EN-CA-24AC
4	Screws (2) 4-40 X 1/8 (Cover)	EN-SCR (2)
5	Frame Cover	EN-FR.C
6	Screw 4-40 x 1/4	EN-SCR
7	Frame**	EN--FR800
8	Assembly Pin*	EN-ASS.PN
9	Spring	EN-SPR
10	Latch Pivot Shaft	EN-LCH-PV-ST
11	Guard	EN-GRD
12	Plastic Cap	EN-PLC
13	Face Plate	EN-800-FACE
14	Mounting Screws (2)	EN-800-MTS

NOTE: Number in parenthesis () indicates part in Parts List.

UL LISTED - 1034 Burglary Resistant Locking Mechanism for Indoor or Outdoor Use

BHMA - Grade 1

NYC MEA 79-01-E

* NOT PART OF ASSEMBLY. USED ONLY DURING DISASSEMBLY OR CHANGING FAIL SECURE ACTION.
 ** UNLESS OTHERWISE SPECIFIED, FRAME IS SUPPLIED AS SATIN STAINLESS STEEL - US32D. SPECIFY OTHER FINISHES AS FOLLOWS: BRIGHT BRASS - US3; SATIN BRASS - US4; DARK BRONZE -10B; BRIGHT CHROME -US26.

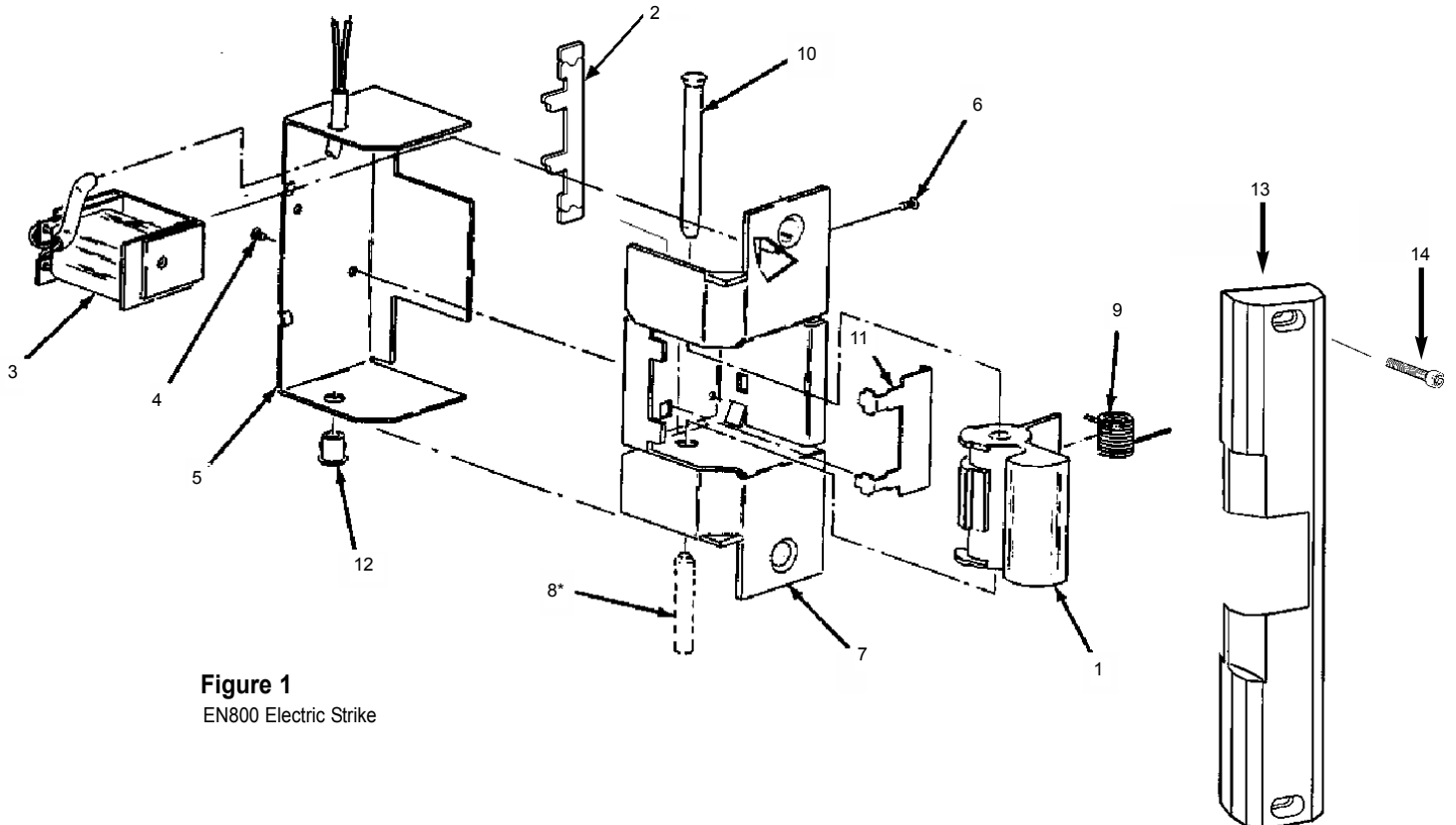
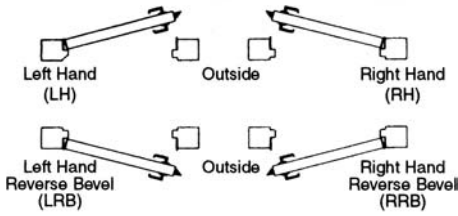

Figure 1
 EN800 Electric Strike

HANDING DETERMINATION

The handing of a door is determined by the position of the hinges, as viewed from the outside of the room, building, office, etc. If the door hinges are on the left, the door is termed left-handed; if the door hinges are on the right, the door is termed right-handed. In addition, a door is either inswinging (opens into the room), or outswinging (opens to the outside of the room), as illustrated in Figure 2.



HAND OF DOOR IS ALWAYS DETERMINED FROM THE OUTSIDE

Figure 2. Door Handing Positions

The position of the Electric Strike within the door jamb will be the same for a right-handed inswinging door and a left-handed outswinging door. For these installations, the Electric Strike position within the door jamb will be as viewed in Figure 3.

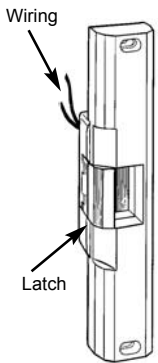
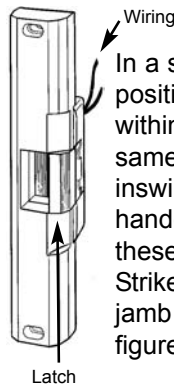

Figure 3. Position of Electric Strike for Right Hand Inswinging and Left Hand Outswinging Door

NOTE:

The EN Electric Strike must be installed with coil assembly up (wiring toward top of unit). In this position, the Electric Strike will be locked without power, Fail Secure, or locked with power, Fail Safe action. Before performing Handing Procedure, view Electric Strike in up position (wire leads at top) to determine if a handing change is required.



In a similar manner, the position of the Electric Strike within the door jamb will be the same for a left-handed inswinging door and a right-handed outswinging door. For these installations, the Electric Strike position within the door jamb will be as viewed in figure (4).

Figure 4. Position of Electric Strike for Left-Hand Inswinging and Right-Hand Outswinging Doors

HANDING PROCEDURE

Perform this procedure only when necessary to change direction of Latch (1, figure 1) in relation to door frame (see figures 3 and 4). Then frame handing is performed by reversing the position of the double ended Slider (2, figure 1) and Coil Assembly (3).

1. Place Electric Strike face down, and from back of assembly, remove two Screws (4) from Frame Cover (5). Remove Frame Cover from Electric Strike, being careful when pulling coil leads (with shrink tubing) through opening in Frame Cover (5).
2. With the cover removed, take note of label marked "Left Hand/Right Hand". The label indicates proper hand orientation of strike frame during procedure, for final coil assembly.
3. On the side of Electric Strike, remove Screw (6), which holds Coil Assembly (3) to Frame (7).
4. Remove Coil Assembly from Electric Strike.

NOTE

The Latch (1) is removed in the following step. Assembly Pin (8) is pushed through Latch to keep Spring (9) in place. If Assembly Pin is not available, use care when removing Latch Pivot Shaft (10) to keep Spring within Latch. If Spring comes out of Latch, reinstall Spring as shown in figure 5.

The four EN latch shims provide cavity width adjustment in 1/16" increments.

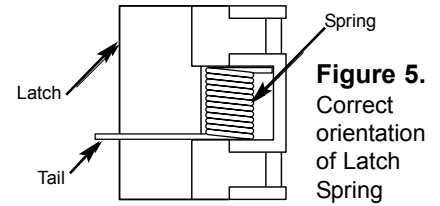

Figure 5. Correct orientation of Latch Spring

5. Place Strike on a flat surface with front of Frame (7) facing up while maintaining orientation for final handing. Insert Assembly Pin (8) into Latch to push out Latch Pivot Shaft (10). Remove Latch (1) containing Assembly Pin.

6. From end of frame remove slider from beneath Guard (11) Figure 6A. Flip slider (reverse ends) and insert through slot in frame, with slider dimple at bottom end of frame. In this position the dimple on slider is at opposite end of frame from coil, at top of frame. The slider in this position maintains the fail secure action, when changing hand.

ACTION (FAIL SECURE OR FAIL SAFE)

The standard action is fail secure and is field changeable by reversing the end of slider during assembly.

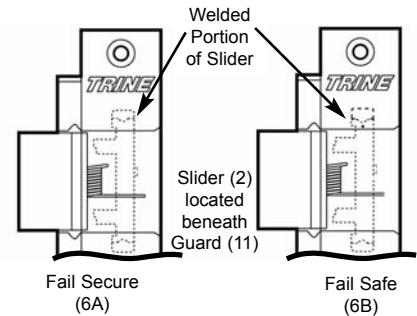

Figure 6.

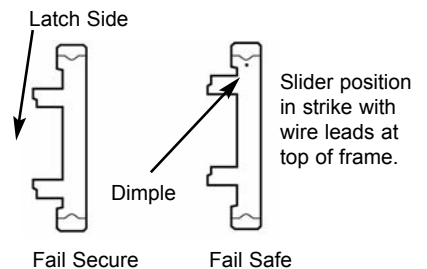

Figure 7.

Hold Latch by satin end side and roll into frame cavity with back end and exposed tip of Spring at the bottom of the cavity. Insert tail end of Spring into hole on the side of frame while replacing Latch.

Take Latch Pivot Shaft with crown end in upright position and insert through shaft hole at the top of the frame "in" selected handing. This will push the Assembly Pin through bottom hole.

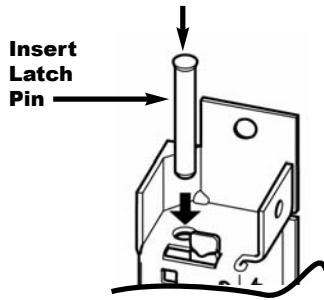

Figure 8.

Place Coil at top of frame, aligning the Coil Bracket threaded hole with the hole in the frame. The Slider tip should rest between the side of Coil and Coil Bracket. Secure Coil to the frame with Coil Assembly Screw (#6).

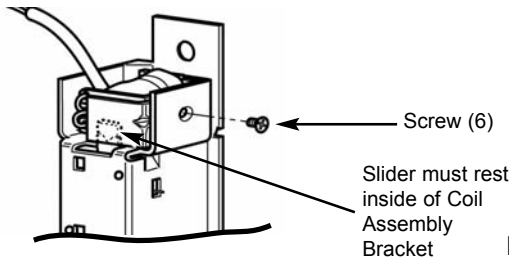

Figure 9.

Check Slider action . Make sure Slider is free to move up and down with no resistance.

Before replacing cover, make sure the unit operates properly by testing with appropriate voltage.

NOTE: Do not attempt to lubricate Electric Strike!!!

Place Strike face down and place wire leads through hole in cover. Attach cover with two screws (4).

INSTALLATION PROCEDURE: - For new or replacement installation in wood or metal jambs.

1. Verify that voltage rating of Electric Strike is compatible with supply voltages of installation. Coil voltages are color coded.

WIRE LEAD	CODE/STRIPE
12AC	Blue/Orange Stripe
12DC	2 Orange Stripe
24AC	Blue/Black Stripe
24DC	2 Black Stripe

2. Using template supplied with Electric Strike, mark door jamb for cutout and screw holes.

NOTE

For proper installation, center line of latchset must be aligned with center line of Electric Strike.

3. Prepare door frame (cut out jamb if required) for Electric Strike. Leave sufficient space for splicing between power supply wiring and Electric Strike wiring.

4. If required, run new wiring to door frame mounting hole. See figure 10 for typical wiring installations. Refer to wiring chart below for correct wire size. (Total wiring length includes routing to door-release push button).

Total Wiring Length to Transformer	12V	24V
Up to 50 Ft	18AWG	20AWG
50 to 150 ft	16AWG	18AWG
150 to 300 ft	14AWG	16AWG
300 to 600 ft	12AWG	14AWG

NOTE

For DC operation, to obtain an audible signal when Electric Strike is energized, install buzzer type BZ-12 for 12VDC operation, or BZ-24 for 24VDC operation (purchased separately), as illustrated in figure 10.

5. Hold Electric Strike upright (wiring toward top) and determine if handing is required. If so, perform handing procedure.

6. Splice Electric Strike wiring to supply wiring. Secure with wire nuts (supplied).

7. For wood and aluminum door jambs, drill pilot holes for securing Electric Strike to door jamb. For steel and aluminum door jambs, secure Electric Strike to existing mounting tabs.

8. Install Electric Strike into door jamb and secure with flat head mounting screws (supplied).

9. Verify that door operates correctly when Electric Strike is energized and not energized.

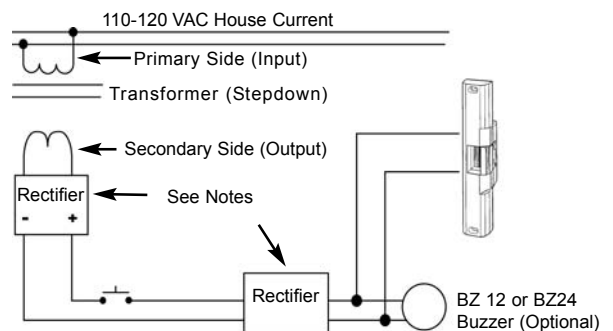

Figure 10.

NOTES:

1. Rectifier can be located either between transformer and push button, or between push button and electric strike.
2. Use either a silicon rectifier or a current-regulating rectifier for converting the AC voltage at the transformer secondary to the DC for operating the electric strike.

ELECTRICAL CHARACTERISTIC CHART

FAIL SECURE (Intermittent Duty) NORMALLY LOCKED

VOLTAGE	CURRENT/AMPS	OHMS	SOUND	DUTY
12VAC	.70	4.5	Buzz	Intermittent
24VAC	.37	18.0	Buzz	Intermittent
12VDC	.28	43.0	Silent	Inter/Cont
24VDC	.15	164.0	Silent	Inter/Cont

TROUBLESHOOTING

Possible Trouble	Probable Cause	Suggested Remedy
Door lockset is not secured by Electric Strike	1. Centerline of lockset not properly aligned to centerline of Electric Strike.	Check for proper cutout installation of Electric Strike by referring to template and door frame and lockset position.
	2. Latch does not project properly into cavity of Electric Strike.	Check for excessive gap between door and jamb. Check that lockset is compatible with EN series cavity and requirements. If necessary, use other type of lockset or Electric Strike (refer to Trine Catalog for more information).
	3. Latch Spring broken or missing.	Hold Electric Strike so that wiring faces down and apply pressure to Latch. Verify that Latch releases and that there is sufficient Spring tension to push it to closed position when released. If Latch does not have Spring tension, disassemble Electric Strike and inspect for improperly installed or broken Spring.
Electric Strike does not energize	1. Wiring to Electric Strike open or shorted.	Check that electrical connections are secure and that no fraying has occurred during installation. Use voltmeter to verify that Electric Strike is receiving energizing voltage and that wiring is not shorted.
	2. Insufficient voltage to Electric Strike.	Verify that voltage rating on Electric Strike label is compatible with voltage from secondary transformer (12V or 24V). If voltages do not match, either replace transformer or change Electric Strike or Coil Assembly. Use voltmeter to verify that Electric Strike is receiving proper voltage and that wiring is not shorted. If voltage is too low because wire size is too small for length or wiring to Electric Strike (see wiring-length data on previous page), either replace wiring or use transformer with higher VA rating.
	3. Slider does not move when Coil receives proper voltage.	Using an OHM meter, verify that resistance of the Coils matches the chart on page 3. If Coil is open (burned out), verify that transformer for Electric Strike has correct voltage current AC/DC and is wired correctly. AC Coils do not operate at continuous duty, or on DC voltage. Check that Slider (2) floats freely, as follows: Remove Electric Strike from jamb and hold with wires facing up. Test that Strike is locked by applying pressure to Latch. Then turn Strike upside down with wires facing down and verify that Latch opens freely by applying pressure. The locking Slider (#2) must float freely for unit to operate properly.
Electric Strike energizes but does not disengage lockset	1. Lockset is applying pressure to Electric Strike, preventing Latch from releasing.	Check for proper cutout installation of Electric Strike. Latch requires proper clearance to open correctly and provide path for Lockset Latch to engage Strike. Check that Lockset Latch is not binding to bottom of Strike cavity due to door sag. Check if foam insulation or the materials around door jamb are preventing door from closing flush, causing door to put pressure on Latch.